

# SBC03 LED STREET LIGHT SERIES



MODEL S



MODEL M



MODEL L



MODEL X

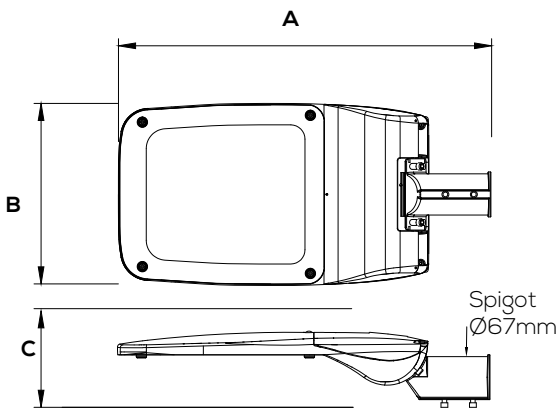

Model	Watt(W)	A(mm)	B(mm)	C(mm)
S	40W-60W	483.2	230.0	113.4
M	70W-100W	548.2	229.8	113.4
L	110W-150W	598.0	257.1	128.7
X	180W-200W	654.6	317.2	215.1

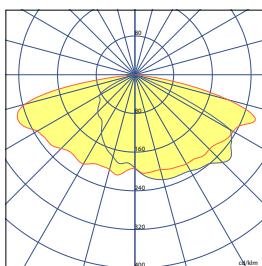
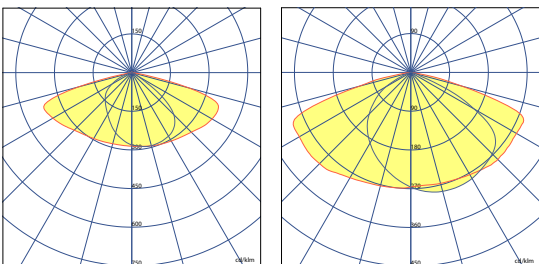

## FEATURES

- Lamp housing is made of aluminum die-casting.
- The whole lamp of the product reaches IP66 waterproof rating.
- Light effect is optional, and the installation method is optional.
- The heat sink and lamp body are integrated, light weight and faster heat dissipation.
- The lamp life is up to 50,000 hours.
- Product warranty for five years.

## THE HEAT SINK IS INTEGRATED WITH THE LAMP HOUSING FOR FASTER HEAT DISSIPATION

The heat sink is integrated with the lamp housing, and the LED is directly connected to the outer casing. The heat dissipation fins and the air convectively dissipate heat through the outer casing, which fully guarantees the service life of the LED street lamp for 50,000 hours.

## WHOLE LAMP SPRAY WATERPROOF TEST

The lamp is designed to effectively dissipate heat, waterproof and dustproof. The surface of the luminaire is UV-resistant and anti-corrosive, and the overall luminaire meets the IP66 standard.

## BUILT-IN SURGE PROTECTOR FOR SAFER USE OF ELECTRICITY

Protection against indirect and direct lightning or other transient overvoltage surges.

<b>MODEL</b>	SBC03-S	<b>DEGREE (°)</b>	T2, T3, T4
<b>INPUT POWER (V)</b>	AC100-277V	<b>DIMMING (Y/N)</b>	Upon Request
<b>FLUX(LM)</b>	140Lm/W	<b>SIZE (MM)</b>	483.2 x 230 x 113.9mm
<b>WATTS(W)</b>	35W-60W	<b>WORKING TEMPERATURE(°C)</b>	-30 C ~ 45 C
<b>PF</b>	0.95	<b>IP RATING</b>	IP66
<b>EFFICIENCY(LM/W)</b>	140Lm/W	<b>IK RATING</b>	0.8
<b>CRI</b>	>70Ra	<b>AVERAGE LIFE (HRS)</b>	50,000 hours
<b>CCT (K)</b>	3000/4000/5000K		

<b>MODEL</b>	SBC03-M	<b>DEGREE (°)</b>	T2, T3, T4
<b>INPUT POWER (V)</b>	AC100-277V	<b>DIMMING (Y/N)</b>	Upon Request
<b>FLUX(LM)</b>	140Lm/W	<b>SIZE (MM)</b>	548.2 x 229.8 x 113.4mm
<b>WATTS(W)</b>	70W-100W	<b>WORKING TEMPERATURE(°C)</b>	-30 C ~ 45 C
<b>PF</b>	0.95	<b>IP RATING</b>	IP66
<b>EFFICIENCY(LM/W)</b>	140Lm/W	<b>IK RATING</b>	0.8
<b>CRI</b>	>70Ra	<b>AVERAGE LIFE (HRS)</b>	50,000 hours
<b>CCT (K)</b>	3000/4000/5000K		

<b>MODEL</b>	SBC03-L	<b>DEGREE (°)</b>	T2, T3, T4
<b>INPUT POWER (V)</b>	AC100-277V	<b>DIMMING (Y/N)</b>	Upon Request
<b>FLUX(LM)</b>	140Lm/W	<b>SIZE (MM)</b>	598 x 257.1 x 128.7mm
<b>WATTS(W)</b>	110W-150W	<b>WORKING TEMPERATURE(°C)</b>	-30 C ~ 45 C
<b>PF</b>	0.95	<b>IP RATING</b>	IP66
<b>EFFICIENCY(LM/W)</b>	140Lm/W	<b>IK RATING</b>	0.8
<b>CRI</b>	>70Ra	<b>AVERAGE LIFE (HRS)</b>	50,000 hours
<b>CCT (K)</b>	3000/4000/5000K		

<b>MODEL</b>	SBC03-X	<b>DEGREE (°)</b>	T2, T3, T4
<b>INPUT POWER (V)</b>	AC100-277V	<b>DIMMING (Y/N)</b>	Upon Request
<b>FLUX(LM)</b>	140Lm/W	<b>SIZE (MM)</b>	654.6 x 317.2 x 215.1mm
<b>WATTS(W)</b>	180W-240W	<b>WORKING TEMPERATURE(°C)</b>	-30 C ~ 45 C
<b>PF</b>	0.95	<b>IP RATING</b>	IP66
<b>EFFICIENCY(LM/W)</b>	140Lm/W	<b>IK RATING</b>	0.8
<b>CRI</b>	>70Ra	<b>AVERAGE LIFE (HRS)</b>	50,000 hours
<b>CCT (K)</b>	3000/4000/5000K		

## INSTALLATION

Vertical / Straight arm mounting

